



**Brief Introduction**

QD-JMY2005 Decode instrument is the latest design of our company. This unit is an portable infrared- remote-controller decoder.It embedded a world first class IC with mass storage and low power consumption.It can be used to test and decode almost all normal infrared-remote-controller, and judge IC model.Small volume、Excellent ID design、Easy carried、Easy operated .It is a necessary tool for remote-control designer, manufacturer, maintenance man and dealer.

**Features**

- A、 Big size LCD display with Chinese explanation, easy to distinguish.
- B、 Complete function.
- C、 Handled by hand, or lay up on desktop by supporter for convenience reading.
- D、 Controller's IC product types are directly displayed on screen.
- E、 Low battery indicator on screen remind you to change new one.
- F、 "QUNDA" lamp flicker for identify the signal received, and the buzzer after the right recoding.
- G、 Auto-power-off after no input last 3 minutes.

**Panel description**

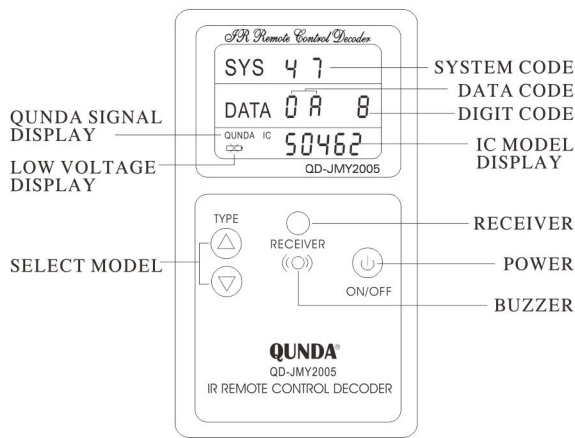

**Operation**

**a. Dispose and replace the battery:**

Two pieces of 5# battery (AA, UM-3, or R06) needed. Install them according to the "+", "-" which marked inside of battery box. After the right install, full LCD display shall last 1 second.

**b. Testing for Infrared rays:**

How to check the controller working or not(test if the infrared emit or not)?

Push down the "power" button, symbol displayed on the screen. Let the tested controller level at the infrared rays receiving window, then press any key of controller, if the symbol "QUNDA" is twinkle on the screen, means the infrared ray emit from the tested controller, otherwise not.

**c. Decode Controller:**

How to know the controller's recording code?

Push down the "power" button, symbol displayed on the screen. push "type" button to select the correct type of IC(or the format of encoding). Let the tested controller level at the infrared rays receiving window, then press certain key of controller. The right code shall show on the "DATA" line for the corresponding tested key, and remind with buzzer.

If the IC type is not known yet, please to identify the IC type at first(follow see below step d.)

**d. Identify the IC Product type.**

How to confirm the IC type of one controller?

Push down the "power" button, symbol displayed on the screen. Let the tested controller level at the infrared rays receiving window, then press certain key of controller. If the buzzer beep,then the type(or the format of code) on the screen is the correct type for the controller. If there is no beep, please select the next type in the list, try again until buzzer, that means you get the right type for your tested controller IC..

**Operation Notes**

- 1) The instrument's power switch is light-tough button. The first pushing is "ON" ( LCD light on ), Another pushing will be "OFF" ( LCD content disappears). The power will shut down after no input last 3 minutes.
- 2) If the "QUANDA" twinkling while no any input, that mean there are strong light source rather than the controller. Please far from strong light source to avoid disturbing.
- 3) User code some is 4 bit, some is 2 bit and sometimes no code, this is the IC original defined. All of them are regular.
- 4) The code data increase continually when decoding (overflow when larger than 9) mean controller emit correctly, otherwise it work abnormally.
- 5) It cannot decode the controller, which are not in the list of attachment.
- 6) When the controller has two or more IC, this instrument can only distinguish one of these IC out and decode.
- 7) When lay up on the desktop, pull out the holder from the back of instrument.
- 8) Take out the battery if long time no use.

**Kindly remind**

When the customer need purchase the controller (specially no-brand one), can choose the other brand with the same IC.  
In the Appendix list the standard IC type for QUNDA IR remote controller.[IC category: 20]

**Technical parameters**

Decode IC kinds: 20kinds  
Power supply voltage: DC3V  
Battery model: Battery (AA、UM-3、R06) ×2  
Dimension: L110mm × W62mm × D20mm  
Weight: Approx.70g (excl. the batteries)

**Manufacturer**

Name: QUNDA Control Technology (Jiangsu) Co., Ltd.  
Address: No.888 LongQiao Road, WuJiang District, SuZhou, China  
Post code: 215200 Web site: www.qunda.com

The final explanatory right is reserved this company. Any alteration on the design and model will not be further notified.



**Attached table**

N O.	IC MODE CODE (FORMAT)	Display usage						Explanation	Best choice model of Qunda	Condition
		IC	5	0	4	6	2			
00	M50462	IC	5	0	4	6	2	MITSUBISHI System Format	QD-CD103	Needn't setup
01	SAA3010	IC	3	0	1	0	-	PHILIPS RC-5 format	QD-CD103	Needn't setup
02	TC9012	IC	9	0	1	2	-	T9028, T9243TOSHIBA format	QD-CD103	Needn't setup
03	M3004	IC	3	0	0	4	-	THOMSON 3004	QD-883	Need setup
04	TC9148	IC	9	1	4	8	-		QD-883	Need setup
05	M50560	IC	5	0	5	6	0	M50560-001,003,008MITSUBISHI Format	QD-M50560	Needn't setup
06	NEC6121/6122	IC	6	1	2	1	-	6121-001,002,003,NEC Format	QD-883	Need setup
07	LC7461	IC	7	4	6	1	-		QD-LC7461	Needn't setup
08	SONY D7C5	IC	8	2	7	-	-	UPD6124	QD-SN02	Needn't setup
09	SONYD7C8	IC	D	7	C	8	-		QD-SN02	Needn't setup
10	SONYD7C13	IC	D	7	C	1	3	SONY disc format	QD-DISC01	Need setup
11	SONY 50119P	IC	5	0	1	1	9		QD-SN02	Needn't setup
12	MN6014W/6030J	IC	6	0	1	4	-	M6014-C5D6	QD-883	Need setup
13	Panasonic 2185	IC	2	1	8	5	-	M6014-C6D6	QD-PN02	Needn't setup
14	Panasonic 2188	IC	2	1	8	8	-	LC7464	QD-PN02	Needn't setup
15	SHARP 0773	IC	0	7	7	3	-		QD-SP02	Needn't setup
16	EW-6BIT	IC	D	6	-	-	-	SHARP 0329, MITSUBISHI ADOPT	QD-883	Need setup
17	JVC C8D8	IC	C	8	D	8	-		QD-JC101	Needn't setup
18	PCA8521	IC	8	5	2	1	-		QD-PH02	Needn't setup
19	Grundig C10	IC	9	1	D	1	0	Same to TP622 format	QD-883	Need setup
20	PIONEER 6121	IC	6	1	2	1	2	PIONEER 6121format, emit data continuously	QD-DISC01	Need setup